

# 1. Dimensional sketches, VEX150

## 1.1 HORIZONTAL VEX

VEX160HL

The principal dimensions are indicated on the following drawing:

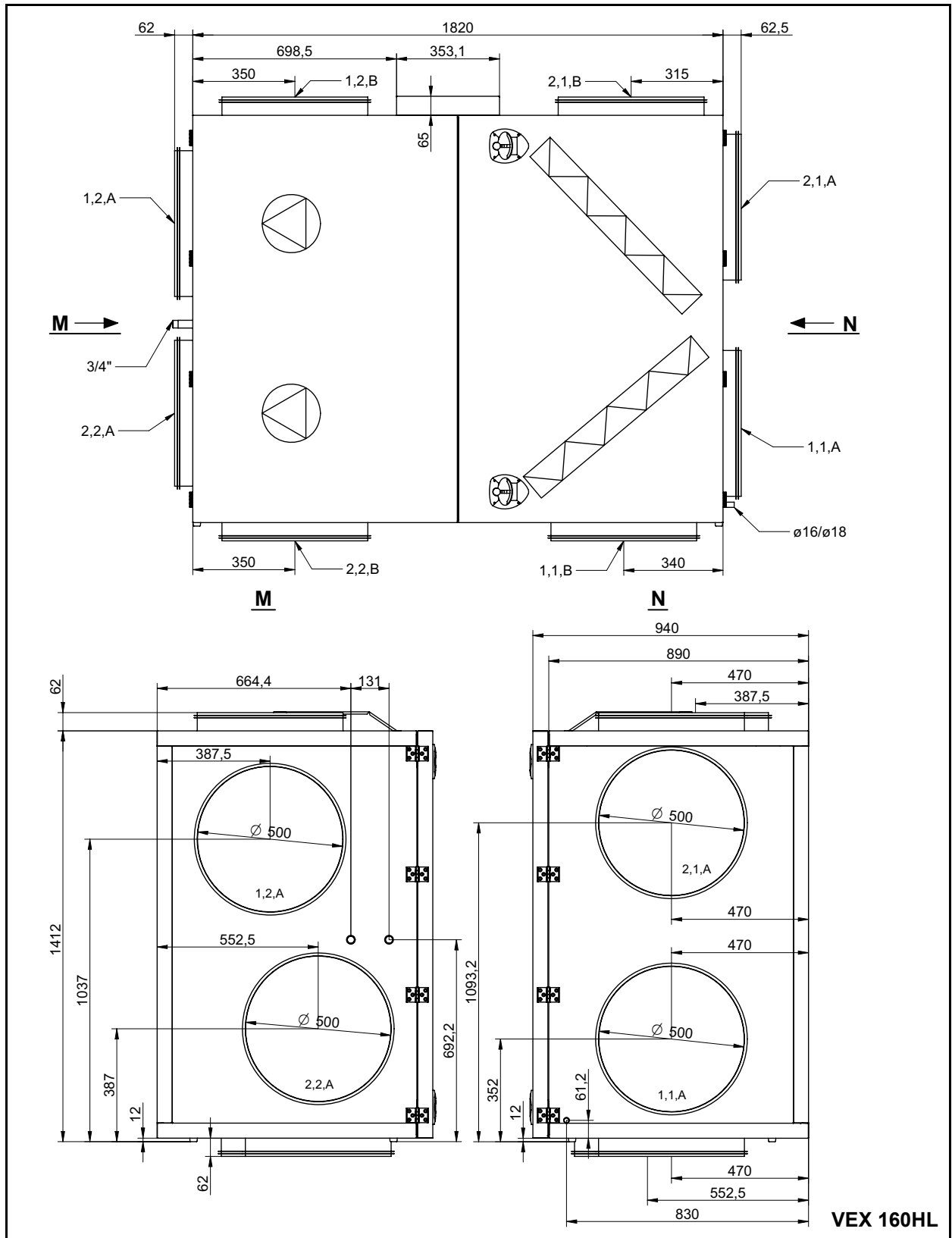

NB

The drawing shows all possible spigot locations.

**VEX160HR**

The principal dimensions are indicated on the following drawing:

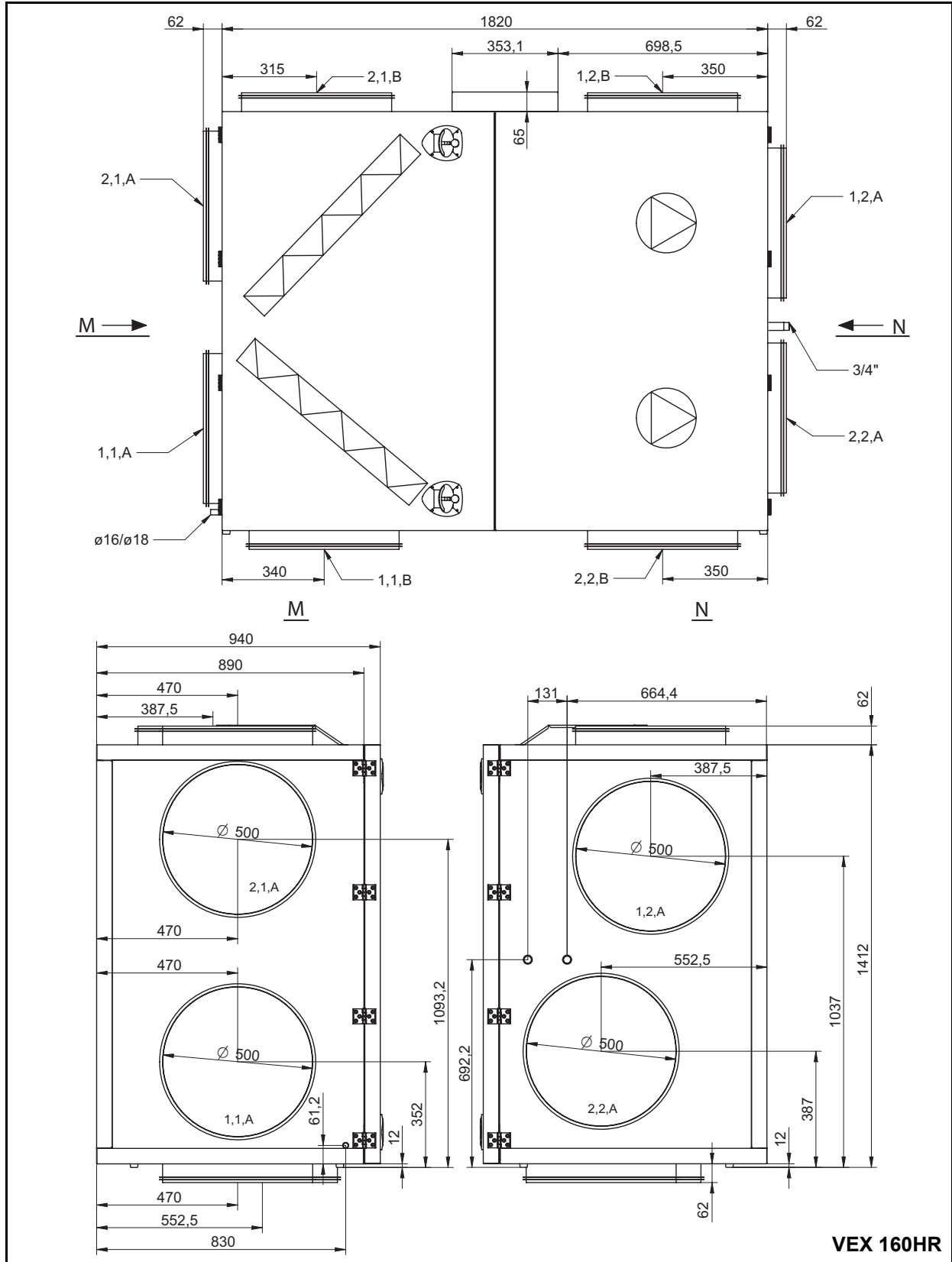

**NB**

The drawing shows all possible spigot locations.

## 1.2 VERTICAL VEX

VEX160VL

The principal dimensions are indicated on the following drawing:

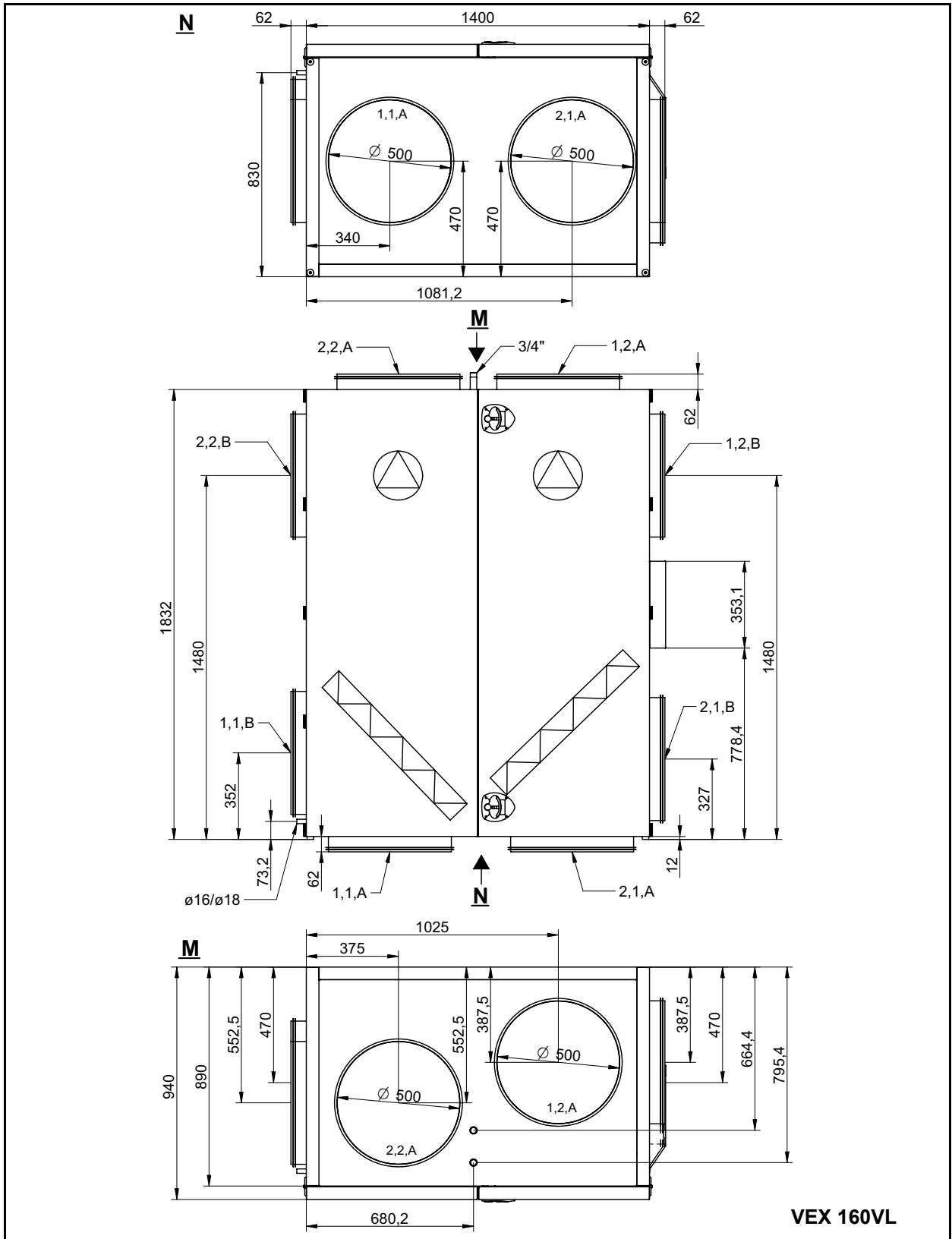

NB

The drawing shows all possible spigot locations.

